



Automatic or semiautomatic palletiser

Autopal

Automatic or semiautomatic palletiser



Semiautomatic model, for pallet change an operator is required.

Low-level automatic or semiautomatic palletiser with the pallet in a stationery position for low production needs. Ideal for cartons, crates, jerry cans and shrink-packed products. The products on infeed are distanced one from the other, orientated, grouped into layers and placed on the pallet in a pre-determined programme.

Flexible

Sweep palletisers with minimal footprint, which can be supplied with high or low level infeed and can be adapted for a wide range of products.

Quick investment return

Due to the rationalisation of the design in both size and operation, the machines have an excellent qualityprice balance allowing a quick payback on the initial investment.

Multi-palletising

In alternative to palletising with the pallet on the ground or directly on the pallet outfeed conveyor, the palletiser can be fitted with a shuttle car system in the layer unloading area with two or more stations to allow different products to be palletised simultaneously on separate pallets.



Acetalic flex chain for layer preformer and lifting device pusher.

Optional:

- High-level infeed
- Multi-pallet stations to palletise different products on different pallets
- Pallet conveyors
- Empty pallet magazine
- Layercard placement device
- Shuttle car system for transport of completed pallets
- Supervision and teleassistance via modem

General technical characteristics

Mechanics speed:	up to 3 cycles/min.
Air consumption 6/7 bar:	about 200 NI/min.
Max. installed power:	6/8 kW

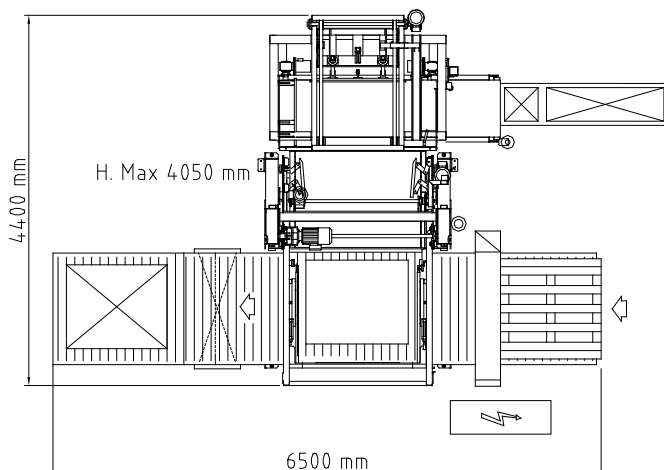

TMG Impianti reserves the right to carry out modifications to specifications and designs at any time and without notice

TMG Impianti S.p.A. via Regia, 5
35018 San Martino di Lupari (PD) ITALY
Tel. +39 049 9467911 Fax +39 049 9467900

Internet: www.tmgimpianti.it
E-Mail: sales@tmgimpianti.it

